

AIタイプ・AIIタイプ・BIタイプ・BIIタイプ・CIタイプ

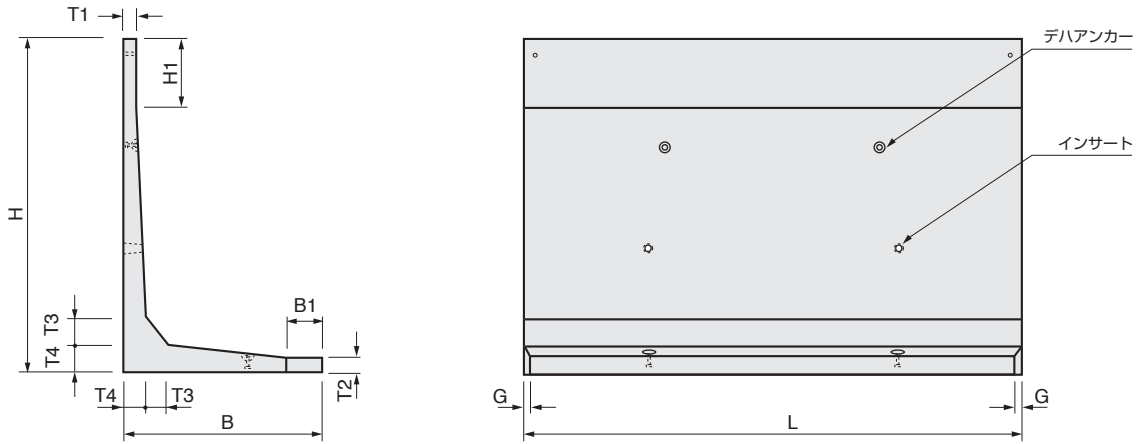

呼び名	寸法(mm)											参考質量(kg)
	H	B	L	H1	B1	T1	T2	T3	T4	G		
1000	AI		800									1750
	AII		1000									1950
	BI	1000	850	4000	-	-	100	100	100	100	30	1800
	BII		1200									2150
	CI		1250									2200
1500	AI		1050			100						2750
	AII		1300			350						3000
	BI	1500	1200	4000	500	250	100	100	125	125	30	2900
	BII		1400			450						3100
	CI		1550			600						3250
2000	AI		1300			100						3940
	AII		1550			350						4190
	BI	2000	1500	4000	500	300	100	100	150	150	40	4140
	BII		1700			500						4340
	CI		1850			650						4490
2500	AI		1600			150						5460
	AII		1800			350						5660
	BI	2500	1750	4000	500	300	100	100	180	180	50	5610
	BII		2000			550						5860
	CI		2150			700						6010
3000	AI		1850			150						7500
	AII		2100			400						7750
	BI	3000	2050	4000	500	350	100	100	225	225	50	7700
	BII		2300			600						7950
	CI		2450			750						8100
3500	AI		2150			150						6110
	AII		2350			350						6260
	BI	3500	2350	2000	500	350	150	150	300	300	-	6260
	BII		2600			600						6450
	CI		2700			700						6520
4000	AI		2400			400						6670
	AII		2600			600						6820
	BI	4000	2650	2000	500	650	150	150	300	300	-	6860
	BII		2900			900						7050
	CI		3000			1000						7120