

TPウォール 基礎付タイプ

H-900~3000

Aタイプ(レキ質土用)外基礎付

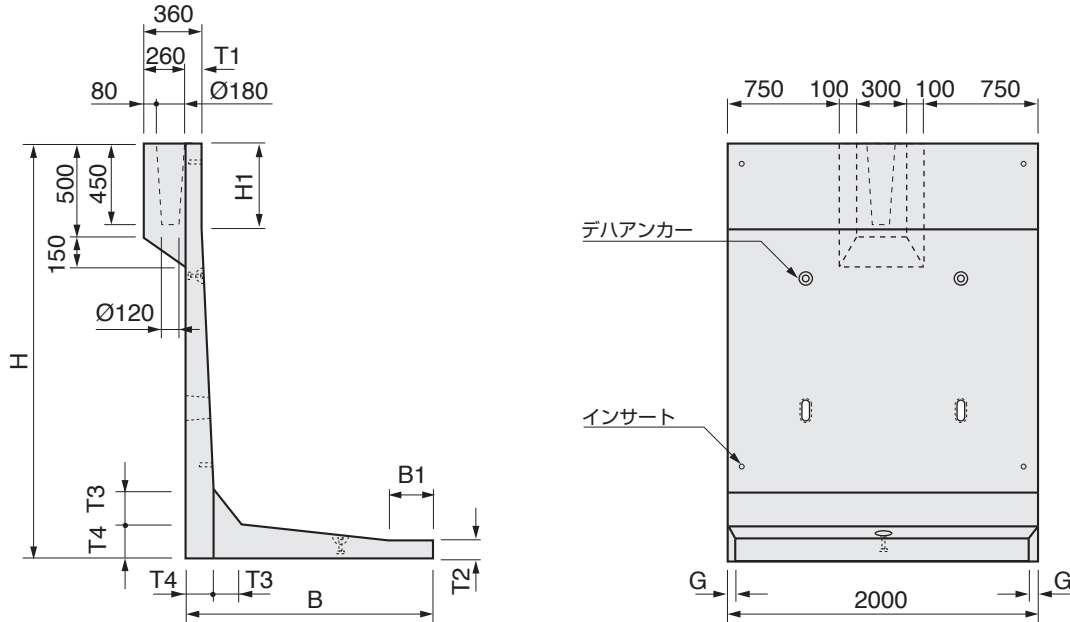

呼び名	寸法 (mm)									参考質量 (kg)
	H	B	H1	B1	T1	T2	T3	T4	G	
900	900		150							1040
1000	1000	1050	250	360					32	1088
1100	1100		350							1136
1200	1200		450		100	100	110	110		1207
1250	1250	1100	500	410					34	1231
1300	1300		550							1255
1400	1400	1150	650	460					35	1325
1500	1500		750							1369
1600	1600	1200	350	110					36	1721
1700	1700	1250	450	160					38	1790
1750	1750	1250	500	160	100	100	150	150	38	1813
1800	1800	1300	550	210					39	1864
1900	1900	1350	650	260					41	1937
2000	2000	1400	750	310					42	2004
2100	2100	1450	350	110					44	2422
2200	2200	1500	450	160					45	2494
2250	2250	1500	500	160	100	100	180	180	45	2517
2300	2300	1550	550	210					47	2563
2400	2400	1600	650	260					48	2636
2500	2500	1650	750	310					50	2704
2600	2600	1700	350	60					50	3317
2700	2700	1750	450	110					51	3391
2750	2750		500		100	100	200	220	51	3414
2800	2800	1800	550	160					53	3496
2900	2900	1850	650	210					55	3566
3000	3000	1900	750	260					56	3635

●底版の120開孔が標準です。開孔数・位置についてはH寸法により異なります。単体図にて確認してください。